

# OsmoBC™ Integrated Membrane Systems For Industrial Wastewater Treatment



## **Fluid Technology Solutions, Inc.**

**OsmoF2O™** FO Membranes

**HBCR™** High Brine Concentrator

**OsmoZLD™** Treatment Process

**INTEGRA™** Disk Filtration

**LTEC™** Crystallizer

# OsmoBC™ Forward Osmosis (FO) Process

## Integrated Membrane Filtration Systems for Industrial Applications

Many industrial waste streams contain precipitating salts like calcium sulfate or polymerized organics such as poly-acrylonitrile. These substances can't be concentrated with Reverse Osmosis unless they have undergone extensive and costly pretreatment. In the case of many of these organic waste streams, the only option is thermal processes such as MVR's followed by incineration or deep well injection.

Forward Osmosis (FO) is a "green" process that uses a semi-permeable membrane to separate water from dissolved solids. Unlike the high-pressure-driven Reverse Osmosis process, Forward Osmosis pulls water molecules through the membrane via osmotic pressure differences and does not require an external pump or hydraulic pressure. FTS' unique patented OsmoBC™

process, which leverages OsmoF<sub>2</sub>O™ FO membrane technology, brings forward osmosis to a wide range of industrial wastewater treatment applications.

The OsmoBC™ process is ideal for filtering high-fouling feed streams with a high content of non-biodegradable BOD, COD, heavy metals, TDS, and TSS like oil and gas wastewaters. It is also capable of generating drinking water quality permeate without excessive pre-treatment, and without significantly degrading flux (water production) rates for long periods of operation.

With today's stringent environmental regulations, industrial plants are challenged to produce clean water and achieve Zero Liquid Discharge in efficient and economical ways.

## The OsmoBC™ Process

The OsmoF<sub>2</sub>O™ FO membrane elements are designed to treat high-fouling feed streams requiring only minimal pretreatment. FTS provides a 100-micron disk filter (INTEGRA™) to remove larger suspended solids and provide pH adjustment if necessary.

A sodium chloride solution is used as a Draw Solution (DS). At typical wastewater solution strengths, a concentration factor of 5-20 is achieved with FO, with permeate recoveries of 80% to 95%. FTS' unique HBCR™ Brine Concentrator system extracts the water

from the brine, and the reconstituted brine is returned to the FO system.

The quality of the resulting permeate is improved by using second- or even third-pass HBCR™ Brine Concentrator systems. When the fouling organics and inorganics begin to come out of solution as the waste stream is concentrated, the foulants can be removed and membrane performance recovered by simple osmotic backwashing and flushing. The final permeate can be discharged to nature or used for process water or irrigation. The final effluent has consistently met stringent permit limits, which are based on regional and country's fresh water quality standards. Concentrate can be solidified (crystallized) and returned to a landfill or discarded via other disposal options.

FTS provides a waste heat driven crystallizer that takes the concentrate from the OsmoBC™ process to crystals. (See the FTS OsmoBC™ Treatment Process diagram on page 6)



OsmoBC™ System



## OsmoF<sub>2</sub>O™ FO Elements\*

FTS' OsmoF<sub>2</sub>O™ spiral elements are made of cellulose and are low-fouling. They process precipitating salts and polymerized organics while having minimal impact on the process. Because of the low FO pressures, they are easy-to-clean with high flux recovery over many cleaning cycles, providing long membrane life.

With the high cost of waste disposal, the OsmoBC™ process is a cost-effective solution for recovering up to 90% of high-quality reuse water while minimizing costly disposal steps.

\* Please refer to OsmoF<sub>2</sub>O FO data sheet for additional information.

FO-CTA-8040-85

## HBCR™ High Brine Concentration and Recovery Elements



HBCR™ High Brine Concentration and Recovery membrane is available as a standalone product or in combination with Forward Osmosis.

When used within a standalone process, an HBCR train is capable of generating up to 200,000 TDS at 1,000 psi (70 bar). In combination with more passes of HBCR, less than 500 TDS permeate is generated while still reaching 200,000 TDS concentrate, thereby minimizing ZLD costs. The most common application is the re-concentration of draw solution in Forward Osmosis membrane system, generating above 140,000 TDS wastewater concentrates.

### Benefits of the OsmoBC™ Process

- Only pretreatment required was 100 micron filter and pH adjustment to 6.5
- Membrane cleaning consisted of daily osmotic backwashing with water and monthly detergent cleaning
- Permeate less than 500 ppm TDS and high enough quality to be used in industrial processes
- Up to 95% recovery, significantly reducing disposal costs
- Reliable and consistent operation
- Stable flux (production rates)

# Target Market and Applications

## Chemical Plants

Effectively treats wastewater from:

- Coal chemical plants
- Chemical and petrochemical plants
- Chlor-alkali plants
- Plastics manufacturing
- Electronic manufacturing ion exchange
- Spent machining cutting fluid and metal forging
- Textile dyes
- Refineries
- Brine concentration and recovery

## Mining

Treatment of production slurries for enhanced recovery and membrane treatment of wastewater, minimizing waste and enhancing water recovery for reuse.

- Valuable mineral concentration and recovery
- Wastewater reuse
- Desalination

## Power Industry

Wastewater treatment for waste minimization, ZLD, and high-quality reuse waters.

- Cooling tower blow-down
- Boiler make-up feed water
- Flue gas desulfurization wastewater

## Water Industry

### Desalination

- Pretreatment to reverse osmosis
- Further concentrate RO reject to enhance overall water recovery rate

### Food and Beverages

Wastewater treatment to recover valuable food solids from wastewater while producing high-quality recycled waters.

- Anaerobic digestate
- Osmotic membrane bioreactors (MBR) effluent
- CIP wastewater

### Oil and Gas Wastewater

**OsmoF<sub>2</sub>O™** FO can de-water complex feed streams, especially those laden with organic compounds and hydrocarbons like in the oil and gas industry. It can also concentrate to high total dissolved solids (TDS) concentrations in produced water without extensive pretreatment steps.

**OsmoF<sub>2</sub>O™** FO combined with HBCR™ treats oil and gas wastewaters, recovering more than 80% as high-quality reuse water, and minimizing trucking and deep well injection costs by up to 80%.

## The OsmoZLD™ Treatment Process

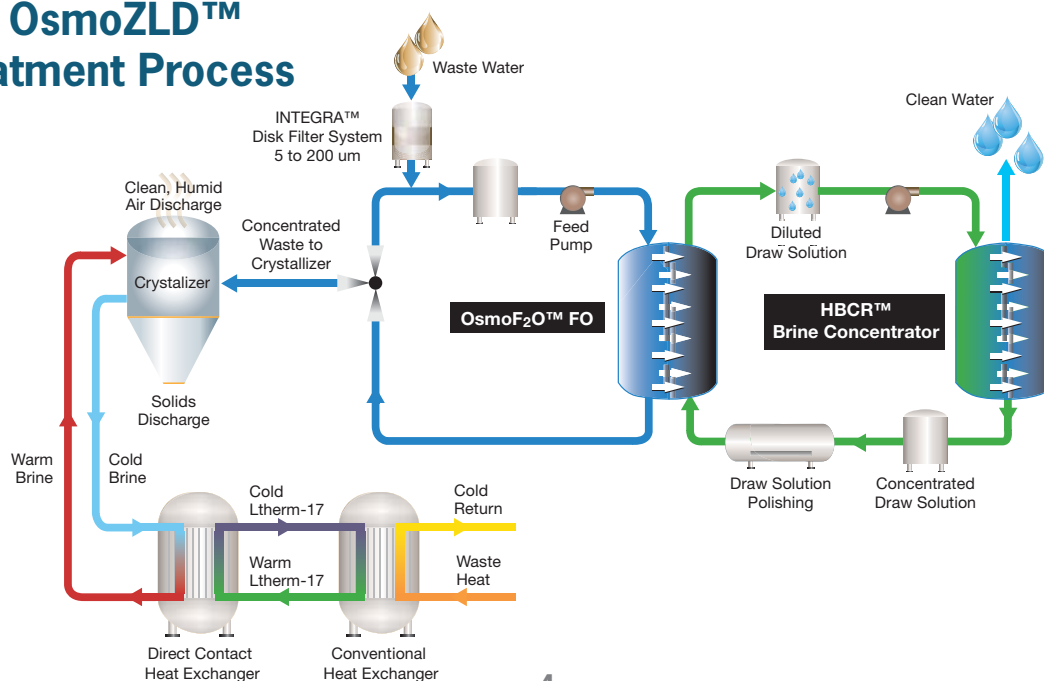



# The OsmoZLD™ Process

Zero Liquid Discharge technologies (ZLD) can help customers meet discharge and water reuse requirements by reclaiming high-quality water and generating solids (crystals) for further use or disposal. FTS' OsmoZLD Process combines the technology of OsmoBC and LTEC. For feed waters that are too challenging for conventional membrane systems, the OsmoBC™ membrane system can concentrate TDS to more than 140,000 ppm.

## Applications include:

- Meeting stringent cooling tower blowdown discharge regulations
- Reduction and solidification of flue gas desulfurization waste water
- Treating and recovering valuable product from chemical waste streams
- Treatment, reduction or elimination of oil and gas industry waste waters
- Other applications

FTS delivers solutions that recover up to 95% of a plant's wastewater while reducing the remaining brine as a product or solid. FTS uses innovative ZLD thermal and non-thermal technologies to help industry manage tough-to-treat wastewaters.

## LTEC™ (Low Temperature Evaporative Crystallization)

LTEC™ treats the concentrates from the OsmoF2O™ FO and HBCR™ Brine Concentrator system to realize zero liquid discharge. LTEC™ is engineered specifically for treatment of highly scaling wastewaters and reject brine streams to achieve zero liquid discharge.

LTEC™ is a low temperature and atmospheric pressure technology capable of employing process waste heat as a ZLD thermal source while also providing high efficiency process cooling. The final product is water vapor to the atmosphere and salt solids.



LTEC™

## Features and Benefits of LTEC™

### FEATURES

- Air driven, evaporative crystallization technology
- Low-temperature operation at atmospheric pressure
- Patented heat and mass transfer technology
- Constructed of common, corrosion-resistant fiberglass and other common plastics

### BENEFITS

- No scaling, no fouling, corrosion-free operation
- Process waste heat used as the thermal energy source
- Enhanced process cooling
- Treats a wide range of wastewaters
- Does not require pressure vessels and associated heavy support structures and associated foundation constraints
- Does not require expensive and hazardous biocides
- Reduces or eliminates the need for large evaporation ponds

## The OsmoBC™ Treatment Process

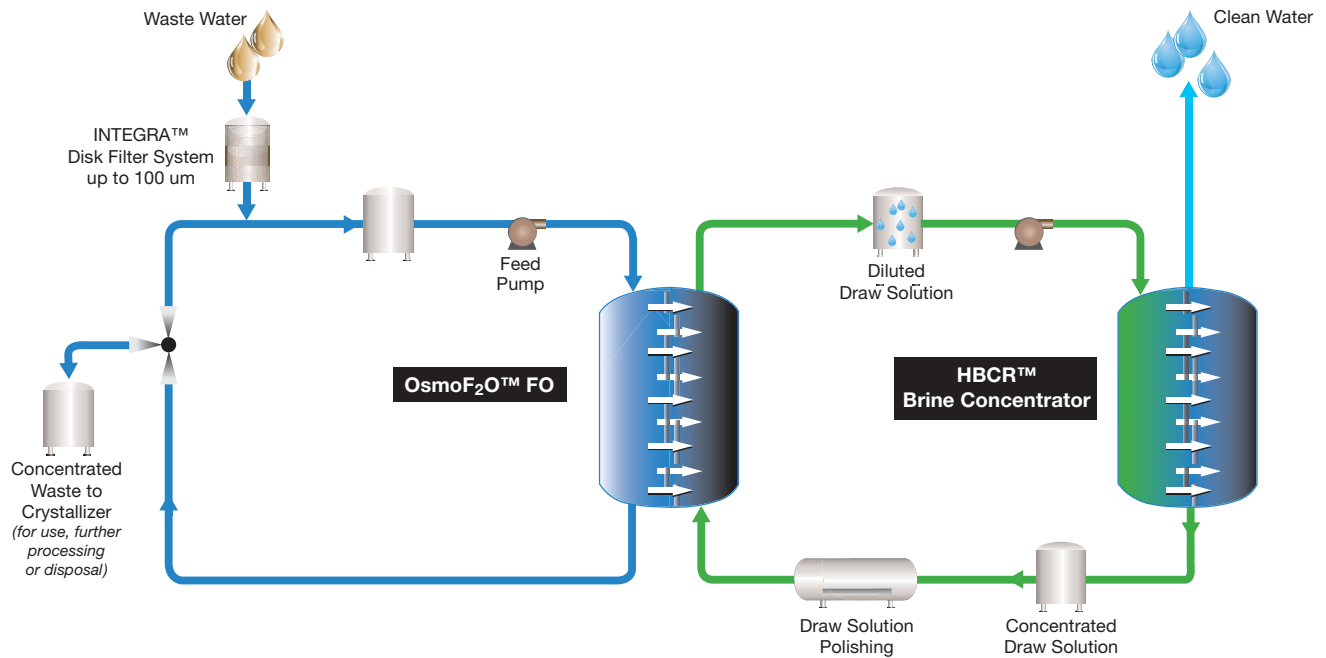

## Challenges of Traditional Wastewater Treatment Processes

- Complicated pretreatment processes for high-pressure Reverse Osmosis systems
- High cleaning chemical consumption required for frequent cleanings of very-high-pressure DTRO treatment systems
- Rapid and permanent flux decline in DTRO systems
- Low water recoveries by DTRO from difficult feeds
- Difficult to treat concentrated sludge
- Difficult to treat high and variable concentrations of dissolved solids, dissolved and colloidal organics, heavy metals, and xenobiotic organics
- High ammonia concentrations
- Non-biodegradable COD
- High salt content and heavy metals cannot be eliminated by biological treatment methods



## Advantages and Benefits

**Forward Osmosis** is a demonstrated wastewater treatment process with more than 15 years of commercial experience and a number of piloting studies around the world which turned into commercial projects with its salient advantages and benefits.



### OsmoF<sub>2</sub>O™ FO and HBCR™ Brine Concentration Membranes:

- Proven commercialized membrane technologies
- Highly hydrophilic membrane characteristics
- The most fouling-, abrasion-, and chlorine-resistant FO membrane
- Unique FO membrane configuration with open feed spacers to allow high flow and reduced risks of clogging or polarization
- Special spacer options for various-viscosity draw solutions
- Can be used in multiple element housings
- More effective cleanings
- Equivalent rejection quality as reverse osmosis (100 molecular weight cut-off)
- Extremely anti-fouling FO membrane can treat highly fouling wastewaters without significant pretreatment

Contaminants	Unit	Feed	Concentrate
BOD	Mg/l	>5000	>20,000
COD	Mg/l	>8,000	>32,000
TDS	Mg/l	Up to 30,000	200,000

- Innovative high brine concentration and recovery HBCR™ Brine Concentrator can concentrate brine up to 200,000 TDS at 70 bar pressure

### Integrated OsmoZLD™ Membrane Process:

#### FEATURES

- Compact modular design, flexible construction, and small footprint
- Automatic control – switch on and off operation



INTEGRA™

#### BENEFITS

- Robust and reliable even with variations of quantity and quality of wastewaters
- Stable fluxes while achieving high recoveries
- Better quality of product water (permeate) than disc tube reverse osmosis system
- Treated leachate permeate can be discharged back to the environment or can be utilized for irrigation or process water
- Eliminates extensive pretreatment by combining OsmoF<sub>2</sub>O™ FO and HBCR™ Brine Concentrator membrane configuration,
- Lower Capital and Operation Costs
- Minimal cleaning requirements, save more than 65% of cleaning costs associated with disc tube RO systems
- For typical wastewaters, higher recovery rates, in many cases, more than 90% recovery at consistent flux rates.
- Final FO concentrate can be less than 10% of the leachate feed
- Economical thermal (crystallizer) processes can be employed to solidify the FO concentrate to less than 4% of the feed
- Low Maintenance Costs — OsmoF<sub>2</sub>O™ FO and HBCR™ Brine Concentration are proven membrane technologies for many challenged waters and fluids
- Reliable pretreatment backwash filter (INTEGRA)

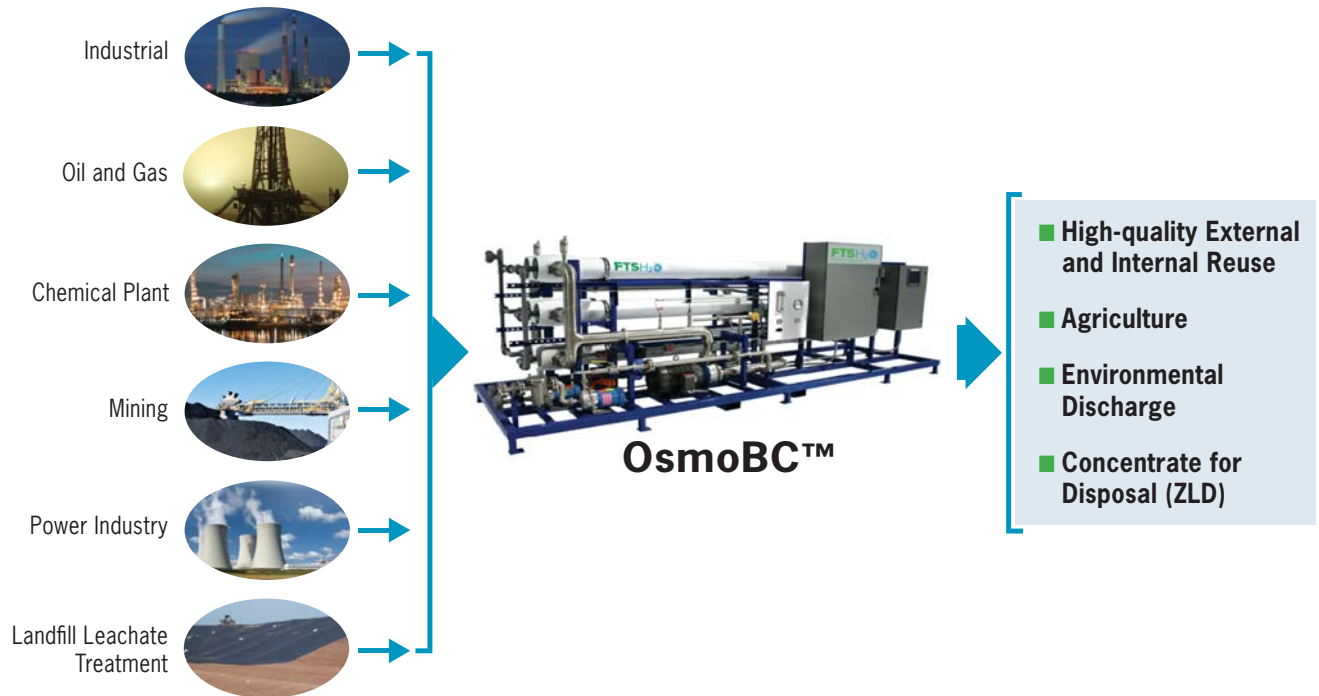

Fluid Technology Solutions, Inc.  
2482 Ferry Street SW | Albany OR 97322 | Phone: 541.791.9182 | Fax: 541.936.3028  
[www.FTSH2O.com](http://www.FTSH2O.com)